

**IT - Generatore d'aria calda ad infrarossi**  
**GB - Radiant hot air generator**  
**DE - Infrarotheizgerät**  
**ES - Generador de calor por Infrarrojos**  
**FR - Générateur de chaleur à l'infrarouge**  
**NL - Infrarood warmeluchtgenerator**  
**DK - Varmluft generator med infrarøde stråler**

***Libretto uso e manutenzione - Operating manual***  
***Bedienungsanleitung - Manual de Uso y Mantenimiento -***  
***Manuel d'instructions - Handleiding voor gebruik en onderhoud -***  
***Brug- og vedligeholdelsesmanuale***

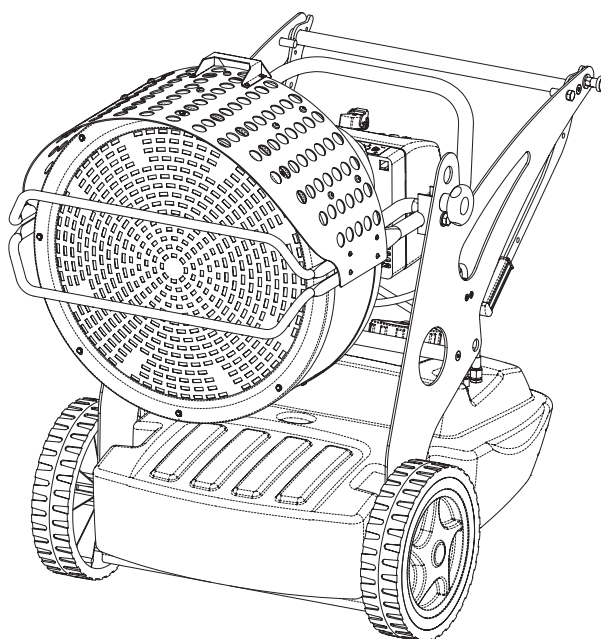

4117.107  
Edition 05  
Rev.2



**IT - IMPORTANTE:** Leggere e comprendere questo manuale operativo prima di effettuare l'assemblaggio, la messa in funzione o la manutenzione di questo riscaldatore. L'uso errato del riscaldatore può causare lesioni gravi. Conservare questo manuale a titolo di futuro riferimento.

**GB - IMPORTANT:** Be sure to read and understand this operating manual before assembling, the set up and functioning or the maintenance of this heater. The misuse of this heater can cause serious injuries. Conserve this manual for future reference.

**DE - WICHTIG:** Lesen und verstehen Sie dieses Handbuch vor der Montage, der Inbetriebnahme oder der Wartung dieses Heizgerätes. Falscher Gebrauch des Heizgerätes kann zu schweren Schäden führen. Bewahren Sie dieses Handbuch für zukünftiges Nachschlagen auf.

**ES - IMPORTANTE:** Leer atentamente este manual de Uso y Mantenimiento, antes de utilizar por primera vez este equipo, prestando mucha atención a todas las recomendaciones indicadas. El uso inadecuado del calentador, puede causar daños graves a personas, animales o cosas. Conservar este manual en lugar seguro y siempre a disposición para futuras consultas.

**FR - IMPORTANT:** lire attentivement et comprendre ce manuel avant d'effectuer l'assemblage, la mise en marche ou l'entretien du réchauffeur. Le mauvais usage de celui-ci peut provoquer de graves lésions. Conserver ce manuel comme futur objet de référence.

**NL - BELANGRIJK:** Bestudeer deze handleiding alvorens het apparaat in elkaar te zetten, in gebruik te nemen, of van een onderhoudsbeurt te voorzien. Verkeerd gebruik van de verwarming kan ernstig letsel tot gevolg hebben. Bewaar deze handleiding voor verdere naslag.

**DK - VIGTIGT:** Denne manuale bør læses og forstås før monteringen, ibrugtagningen eller vedligeholdelsen af dette varmeapparat udføres. Et ukorrekt brug af varmeapparatet kan medføre alvorlige personlige skader. Opbevar denne manuale for yderligere henvisninger.

***XL9 E - XL9 S***

**OESA**

## INDEX

PRODUCT PRESENTATION	9
UNPACKING	9
SAFETY INFORMATION	10
PRODUCT IDENTIFICATION	11
COMBUSTIBLE	11
THEORY OF OPERATION	12
OPERATING INSTRUCTION	12
SAFETY DEVICE	12
MOVING AND TRANSPORTATION	12
PREVENTATIVE MAINTENANCE SCHEDULE	13
ACCESSORIES	14
FAULTS AND THEIR LIKELY CAUSES	15

## PRODUCT PRESENTATION

XL9 is a generator of heat by radiation. Radiation technology is based on the same physical principle behind the warmth of sunlight. The sun heats bodies without a flow of warm air but by waves of radiation. The radiation method is becoming highly popular among professional clients because of the countless advantages it offers. XL9 was designed on the basis of this physical principle and has become irreplaceable in environments which require a constant, even source of heat for warmth, defrosting and drying. In addition, its extremely low noise level makes it suitable for working without having to put up with the noise that other types of heater normally produce. The generator has rubber wheels for ease of movement and it can also be raised and set at different heights by means of eyebolts. Its extended autonomy and automatic thermostat function grant the operator maximum freedom of use. The external fuel-tank indicator provides an easy check on whether fuel needs topping up. The S model has a dual power device that enables a more efficient use of the machine under different conditions and during the various seasons of the year.

## UNPACKING

- Remove the supports used to pack the appliance (Fig. 1).
- Open top side of the box.
- Remove the cardboard from the top.
- Remove the supports that hold the generator to the pallet (Fig. 2).
- Delicately lower the heater off the pallet.
- Dispose of the material used to pack the generator according to the current government regulations in your area
- Check the machine for eventual damages incurred during transportation, if the machine appears damaged immediately inform the store where you purchased it.

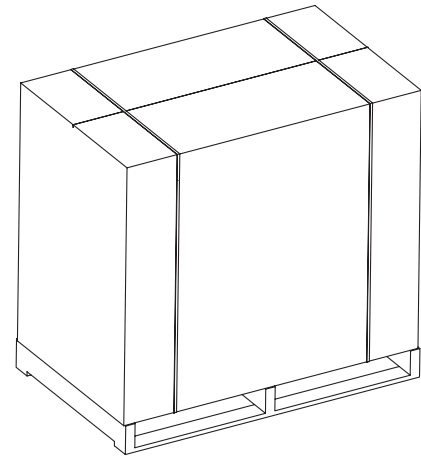

**Figur 1 - Packaging XL9.**

### **OR SHIPPING AND STORING**

- If the generator needs to be placed in storage, or if it has suffered major damage in transport, or needs to be repaired:
- Check for damage, in particular of a nature which could cause loss of fuel. In this case, empty the tank of the remaining fuel.
  - For storage, place the generator on the same pallet from which it was unpacked and, for return, on any suitable EPA-branded euro-pallet.
  - Firmly anchor the generator to the pallet (Fig. 2).
  - Whenever possible, slide the cardboard packing from the top down over the pallet and anchor it firmly using suitable materials (Fig. 1).
  - Store the machine in a suitable, dry place and do not stack more than two. Despatch the generator preferably as shown Fig. 1 or at least as shown in Fig. 2.

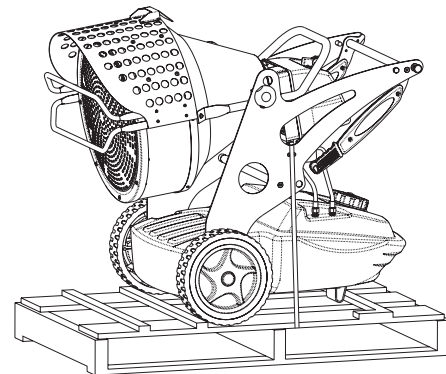

**Figur 2 - XL9 on pallett.**

## SAFETY INFORMATION

## WARNING

**IMPORTANT: Read this entire manual carefully before operating or effectuating any maintenance procedures on this generator. The misuse of the generator can cause serious of fatal injuries due to burns, fires, explosions, electrical shock or asphyxiation from carbon monoxide.**

**DANGER: carbon monoxide asphyxiation can be fatal!**

**Carbon Monoxide Asphyxiation**– The first symptoms of carbon monoxide asphyxiation are similar to that of the flu, headaches, dizziness and/or nausea. These symptoms could be caused by the malfunctioning of the generator. **In this case go outside immediately!** Have the generator repaired. Then you may start it again. Some people are more affected by the effects of carbon monoxide than others, especially pregnant women, those who suffer from heart or lung disease or anaemic people; also those who have consumed alcoholic beverages, and those who are at high altitudes. Be sure to read and understand all of the warnings. Conserve this manual for future reference: it will provide you with instructions to operate your generator safely and correctly. Use only kerosene or diesel to diminish the risk of fire or explosion. Never use gasoline, naphtha, paint thinners, alcohol or other highly flammable combustants.

- Filling the Tank.
  - a) The personnel charged with filling the tank should be qualified and completely familiar with the factory instructions and the current governmental regulations regarding the secure provision of generators.
  - b) Use only the type of fuel expressly specified on the identification plate located on the generator.
  - c) Before filling the tank, extinguish all of the flames, including the pilot light and wait for the generator to cool down.
  - d) While filling the tank inspect all of the fuel lines and their junctions to check for fuel losses. Any losses must be repaired before starting the generator again.
  - e) Under no circumstances should you conserve a quantity of combustible superior to that which is necessary to maintain in function the heater for one day in the same building or nearby the heater. The fuel storage cisterns should be located in a separate building.
  - f) All of the fuel tanks should be located a minimum safety distance from the heater, (like current government regulation), as well as oxyhydrogen blowpipe/ torches, welding equipment and similar ignition sources (with the exception of the fuel tank incorporated in the generator).
  - g) The fuel should be stored in areas where the flooring will not soak up any fuel spills or any drips of fuel line, the flame underneath that could cause a fire.
  - h) All fuel storage must be effectuated in compliance with the current government regulations.
    - Never use the generator in rooms where gasoline, paint thinner, or other highly flammable materials are located.
    - While the heater is in use follow all of the local ordinances and current government regulations
    - Heaters used close to large pieces of fabric, curtains or other similar materials must be situated at a safe distance from these objects. The minimum safety distance is that which is

advised by the current regulations in the your country. It is also advisable to use fireproof materials for coverings. Such materials should be fastened in a safe manner, so as to avoid their catching fire and prevent interference with the generator caused by wind.

- Use only well ventilated areas. Predispose an opening or at least an air exchange system that meets the current governmental regulations in your area so that fresh air will be provided.
- Supply the generator with the proper voltage and frequency as specified on the identification plate.
- Use only extension cords with three wires correctly connected to a grounded plug.
- The minimum safety distance is the distance required by the current governmental regulations in your area.
- Place the generator in a position so that when it is hot or in function it will be on a stable and level surface, so that you avoid starting a fire
- When you move or store the generator, maintain it in a level position in order to avoid fuel loss.
- Keep children and animals away from the generator.
- Disconnect the generator when it is not in use.
- When it is controlled by another device (like a thermostat or a timer), the heater could turn itself on at any time.
- Never place the generator in inhabited rooms.
- Never obstruct the aspiration or dissipation vents.
- When the heater is hot, connected to the power supply or in function it should never be moved, handled, or refilled and no maintenance should be performed on it.
- Smoke that is produced from the first combustion is due to the evaporation of organic materials (ceramic) present in the combustion tank and anticorrosion oil present on the surface of the burner. After a few minutes the smoke will stop.
- The environmental operating temperature is  $-30^{\circ}\text{C} + 30^{\circ}\text{C}$

PRODUCT IDENTIFICATION

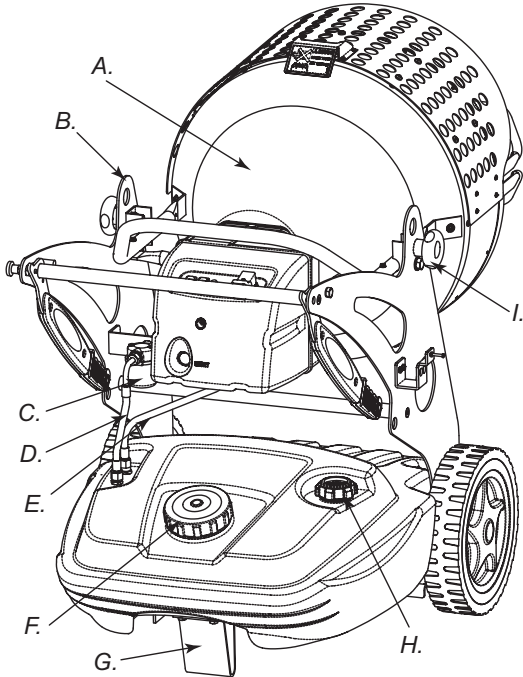

Figur 3 - Model XL9 back view.

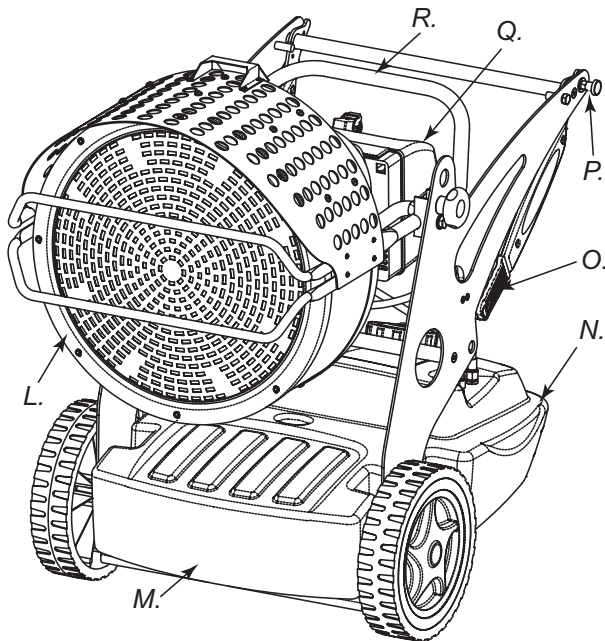

Figur 4 - Model XL9 front view.

A. Combustion chamber, B. Hole for raising generator, C. Fuel filter or pre-heated filter (optional), D. Fuel supply, E. Fuel Return, F. Fuel tank cap, G. Foot or wheel (optional), H. Fuel level indicator, I. Block of the group combustion, L. Radiant deflector, M. Fuel drain plug, N. Fuel tank, O. Handle to move the generator, P. Hinge block, Q. Burner, R. Inclination regulator.

IDENTIFICATION OF THE BURNER PARTS XL9 E - S

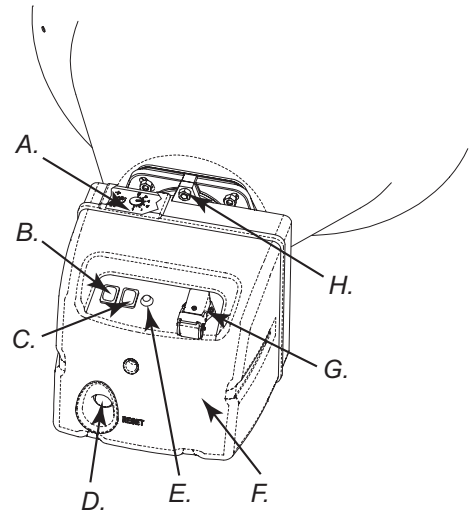

Figur 5 - Function controls XL9.

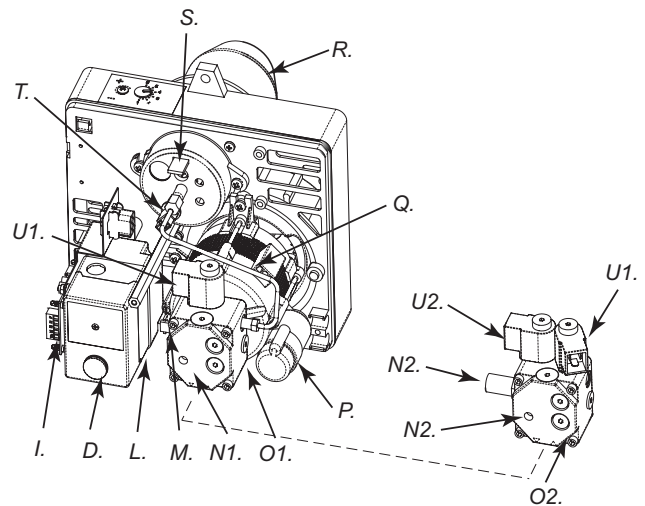

Figur 6 - Components burner XL9.

A. Air vent regulator, B. Lighted ON/OFF button, C. ON/OFF switch depending on power option, D. RESET Button, E. Power indicator, F. Burner coffer, G. Thermostat plug, H. Screw for burner block, I. Post-ventilation device, L. Flame control device, M. Transformer, N<sub>1</sub>. Pressure regulator P<sub>1</sub> of the pump, N<sub>2</sub>. Pressure regulator P<sub>2</sub> of the pump, O<sub>1</sub>. XL9 E fuel pump, O<sub>2</sub>. XL9 S fuel pump, P. Condenser, Q. Motor, R. Burner tube, S. Combustion head regulator, T. Photo-resistance, U<sub>1</sub>. Electrovalve 1° flame step, U<sub>2</sub>. Electrovalve 1° flame step.

COMBUSTIBLE

**WARNING: The generator runs ONLY on kerosene or diesel fuel.**

The use of impure combustibile can cause:

- blockage of the combustibile filter and nozzle;
- formation of carbonaceous deposits on the electrodes;

At low temperatures use non-toxic antifreeze.

## THEORY OF OPERATION

The ventilation needed for proper combustion is produced by a fan inside the burner. The air exits the burner sleeve and mixes with the fuel which is nebulised by a high-pressure nozzle. The fuel is aspirated from the fuel tank by a rotary pump which forces it at high pressure up to the nozzle for nebulisation.

## OPERATING INSTRUCTIONS

**WARNING: Before putting the generator in function, and therefore before connecting it to the electrical system, you must check to see if the electrical systems technical characteristics correspond to those on the identification plate of the generator.**

### STARTING THE GENERATOR

1. Follow all of the safety information.
2. Fill the tank with diesel fuel or kerosene.
3. Close the fuel cap
4. Plug the alimentation cord into a grounded wall plug with the same tension as the one written on the generator's identification plate.

### STARTING WITHOUT A THERMOSTAT

#### • BURNER XL9 E

Set the switch (B Fig. 5) to the ON position (I). It begins the period of pre-ventilation and after approximately 10 seconds the combustion has beginning.

#### • BURNER XL9 S

**WARNING: Before starting the generator to make sure that the button (C Fig. 5) is in position .**

Set the switch (B Fig. 5) to the ON position (I). It begins the period of pre-ventilation and after approximately 10 seconds the combustion has beginning.

For having the maximum potentiality portare set the switch (C2 Fig.5) to the  position.

### STARTING WITH A THERMOSTAT

Regulate the thermostat or the control device (for example a timer), if connected, so that it will allow the generator to function.

**WARNING: The generator can ONLY function automatically when the control device, for example a Thermostat or a Timer, is connected to the generator. To connect the control device to the machine consult the paragraph entitled "ELECTRIC DIAGRAM".**

Before starting the machine or after the fuel line has been completely emptied, the fuel flow to the nozzle should be insufficient to cause the intervention of the security device which controls the flame (see the "SAFETY DEVICE" paragraph) that stops the generator. In this case, after having waited approximately one minute, push the Reset button (D Fig. 5 and 6) and start the machine.

If the machine isn't working you should first control the following:

1. Make sure that the fuel tank (N Fig. 4) still contains fuel;
2. Press the Restart button (D Fig. 5 and 6).

If the generator still isn't functioning consult the "FAULTS AND THEIR LIKELY CAUSES" paragraph to identify the cause.

**WARNING: Before the second ignition (generator extinguished and adequately cold) to assure the blocking of the screws that block the anterior deflector (L Fig. 4).**

**WARNING: The electric power that feeds the generator must be grounded and have a differential magnetic-thermal switch. The generator's electric cord must be attached to a plug equipped with a section switch.**

### TURNING THE GENERATOR OFF

Turn the switch (B Fig. 5) to the OFF position (O) or turn the thermostat or control device (Timer) off if there is one connected. The flame will go out and the ventilation will continue until it has finished its post-ventilation cycle (cooling down).

**WARNING: Before unplugging the alimentation cord from the wall, wait until the post-ventilation cycle is completely finished (it will take approximately 3 minutes to cool down).**

## SAFETY DEVICE

The generator is equipped with a safety device (L Fig. 6), which controls the flame. If one or more anomalies occur when the generator is functioning, the device will block the burner and the RESET button (D Fig. 5 or 6) will light up.

The generator also has a post-ventilation device which enables optimal, automatic cooling of the combustion chamber for some 3 minutes.

Before turning the generator on again you must identify and eliminate the cause that blocked the machine.

## MOVING AND TRANSPORTATION

**"NOTICE: before raising or moving the machine ensure that the fuel tank caps (F and H Fig.3) are firmly closed".**

### TRANSPORT

The generator is easy to move and it may be fixed in a raised position thanks to its special eye-bolt mechanism (B Fig. 3 or Fig. 7). This enables it to be set in the most suitable position for heating, defrosting and drying.

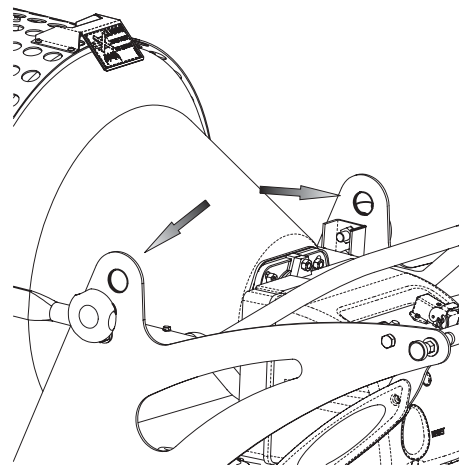

Figur 7 - Hooks in order to raise.

### MOVEMENT

Before picking up or moving the machine you must check to insure that the tank caps (G Fig. 3) are tightly shut. The generator may be supplied with a rotating wheel. In this case, if the flooring allows it you may push the generator like a cart. In the case the machine does not have rotating wheels it is necessary to

unblock the hinge (P Fig. 4) located on one of the lateral struts of the generator. Lower the handle from its "resting position" (Fig. 8) Turn the handle to the "Transportation Position" (Fig. 9). Lift the generator and position it so that it is resting on the two anterior wheels.

**WARNING: Before moving the machine you must: turn the machine off by following the indications provided in paragraph "TURNING OFF THE GENERATOR"; unplug the electrical source by pulling the plug out of the wall and waiting for the generator to cool down.**

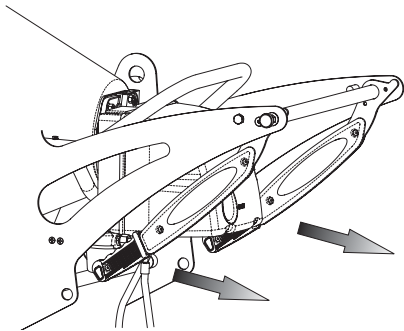

Figur 8 - Position close handles XL9.

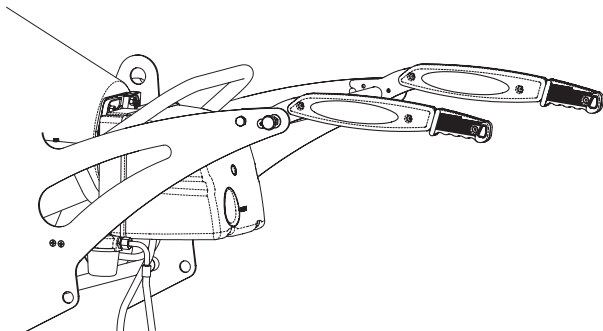

Figur 9 - Position open handles XL9.

## PREVENTATIVE MAINTENANCE SCHEDULE

**WARNING: Before beginning any maintenance operation you must: turn off the machine following the instructions in the "TURNING OFF THE GENERATOR" paragraph; unplug the electrical alimentation by unplugging the cord from the wall plug and waiting for the generator to cool down.**

The instructions in this paragraph regarding the time between service checks depend a lot on the cleanliness of the fuel and the type of environment the generator is used in – the times given are for well-ventilated environments with little dust and considering the use of clean fuel.

Every 50 hours of operation you must:

- Dismantle the on-line cartridge (see "CLEANING THE FUEL FILTER") extract and clean the cartridge;

Every 200 hours of operation you must:

- Dismantle the pump filter (see "CLEANING THE PUMP FILTER") extract and clean it;

Every 300 hours of operation you must:

- Dismantle the burner and clean inside the burner's tube, the flame disk and the electrodes regulating, if necessary the distance (see "CLEANING OF THE BURNER").

### CLEANING THE FUEL FILTER

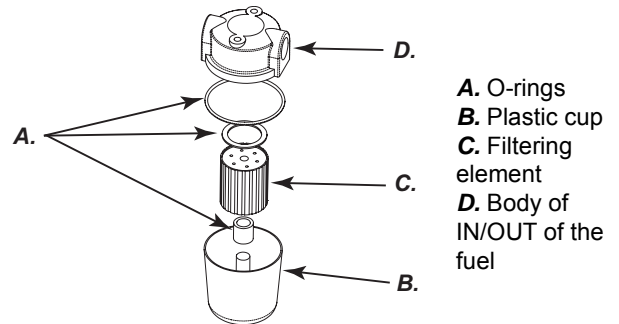

Figur 10 - Filter XL9.

- Unscrew the plastic cup and extract the filtering element (cartridge);
- Clean it well with kerosene;
- Insert the filter element back into its place and screw the cup back into the main body of the combustion filter.

### CLEANING THE PUMP FILTER

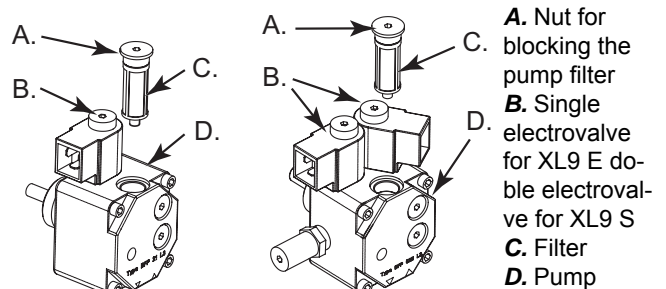

Figur 11 - Pomp of burner XL9 E and XL9 S.

- Dismantle the burner coffer (F. Fig. 5), to identify the pump of the burner (O<sub>1</sub>. o O<sub>2</sub> Fig. 6);
- Unscrew the nut (A Fig. 11) that blocking the filtering element to the pump;
- Extract the filtering element (C Fig 11) outside its place;
- Clean it well with kerosene;
- Insert the filtering element back into its place and screw the nut to the pump.

### CLEANING THE BURNER

- Remove the screw (H Fig. 5) that blocks the burner (A Fig. 3) in the combustion chamber;
- Extract the burner from the combustion chamber (Fig. 3);
- Remove the three screws ( B Fig. 12) that hold the burner tube (A Fig. 12);

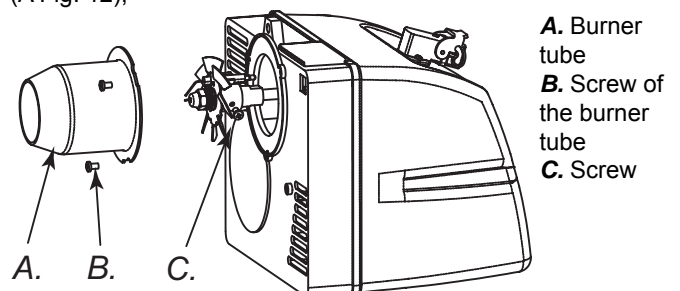

Figur 12 - Disassembly shell-burner.

- Dismantle the tube;
- Remove the screw (C Fig. 12) that holds the group diskflame-electrodes and pull out the nozzle holder (see Fig. 13);
- Clean the flame disk (D Fig. 14) and the electrodes (E Fig. 14);
- Unscrew the nozzle (G Fig. 14) from the nozzle holder (F Fig. 14) clean it and if necessary replace it;

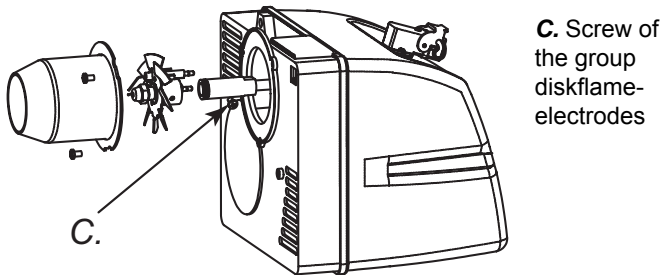

Figur 13 - Disassembly group diskflame-electrodes.

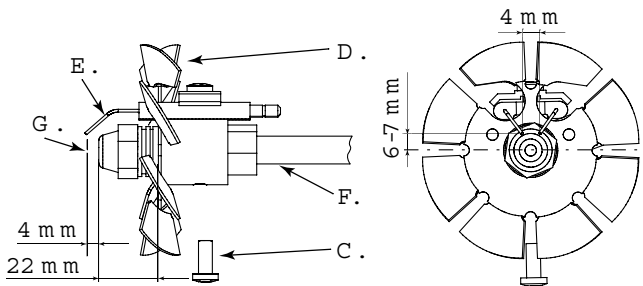

C. Screw, D. Flame disk, E. Electrodes, F. Tube, G. Nozzle

Figur 14 - Distances electrodes nozzle.

- Mount the nozzle (G Fig. 14) in its holder;
- Remount the group diskflame-electrodes placing it at a correct distance as the illustration (Fig. 14) shows.

## ACCESSORIES

### THERMOSTAT

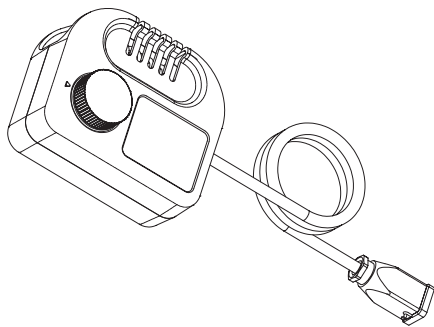

### CONNECTING THE CONTROL DEVICE

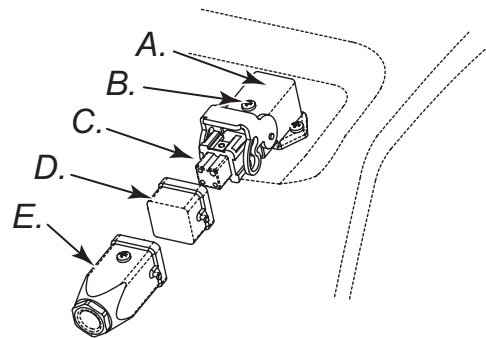

**WARNING:** Before beginning any maintenance operation you must: stop the machine according to the instructions provided in the paragraph "TURNING OFF THE GENERATOR"; disinsert the electrical supply by unplugging it and waiting for the generator to cool down.

- Take the cap off (D) the connecting plug(A);
- Remove the screw (B) and take off the internal product remove the internal part (C).
- Disconnect the wires from clamp 2 and connect the black wire to clamp 2 and the white wire to clamp 3 with a bridge that goes from the last clamp to clamp 1.
- Insert the internal part (C) in the attachment plug (A) and replace the screw (B).
- Insert the Thermostat plug.
- Insert the plug (E) of the room thermostat or of a different control device (timer).

### PRE-HEATING FILTER

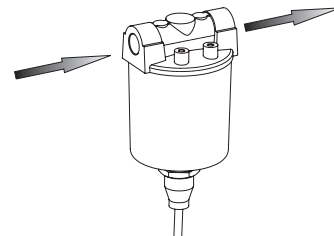

### ROTATING WHEEL WITH BRAKES

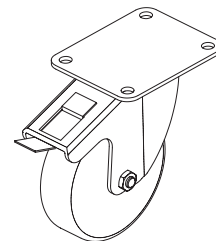

## FAULTS AND THEIR LIKELY CAUSES

**WARNING:** Before beginning any maintenance operation you must: stop the machine according to the instructions provided in the paragraph “TURNING OFF THE GENERATOR”; disinsert the electrical supply by unplugging it and waiting for the generator to cool down.

Symptoms	Possible cause	Solution
The machine stops with flame. RESET button (D Fig. 3 o 5) on.	<ol style="list-style-type: none"> <li>1) Photo-resistance circuit is broken or the Photo-resistance is dirty with smoke residue.</li> <li>2) Dirty fuel filter.</li> <li>3) Flame Control device Circuit is broken.</li> <li>4) Flame disk or tube (Fig. 14, 15, 17) dirty.</li> </ol>	<ol style="list-style-type: none"> <li>1) Clean or replace the Photo-resistance.</li> <li>2) Remove filter and clean it.</li> <li>3) Replace the flame control the circuit.</li> <li>4) Dismantle and clean it.</li> </ol>
The machine stops, spraying fuel without verifying the flame. RESET button (D Fig. 3 o 5) on.	<ol style="list-style-type: none"> <li>1) The electrical system is not compatible.</li> <li>2) Ignition Transformer (M Fig. 4 o N Fig. 6) disconnected or broken.</li> <li>3) Ignition Transformer wires short circuit to ground.</li> <li>4) The electrodes are not at the proper distance.</li> <li>5) The electrodes short circuit to ground because they are dirty or the insulation is damaged.</li> </ol>	<ol style="list-style-type: none"> <li>1) Verify the entire circuit.</li> <li>2) Replace it.</li> <li>3) Replace it.</li> <li>4) Reposition them at the correct distance (see Fig. 15).</li> <li>5) Clean them or, if necessary replace them.</li> </ol>
The machine doesn't spray fuel and stops. RESET button (D Fig. 3 o 5) on	<ol style="list-style-type: none"> <li>1) Photo-electric cell sees a strong source of light</li> <li>2) The power supply is missing a phase to the motor.</li> <li>3) Fuel is not arriving to the pump.</li> <li>4) No fuel in the tank.</li> <li>5) Nozzle clogged.</li> </ol>	<ol style="list-style-type: none"> <li>1) Place the machine so that the light source does not directly face the front deflector.</li> <li>2) Control the electric system.</li> <li>3) Control the fuel supply lines (D Fig.2).</li> <li>4) Resupply the fuel tank.</li> <li>5) Dismantle and clean or replace it.</li> </ol>
The burner doesn't start.	<ol style="list-style-type: none"> <li>1) The control device (Thermostat or Timer) is on.</li> <li>2) Short circuit in Photo-resistance (T Fig. 4 o P Fig. 6).</li> <li>3) Power loss due to: disconnected switch (4) or disconnected main switch due to power loss in the line.</li> <li>4) The installation of the control device (Thermostat or Timer) is not correct.</li> <li>5) Break inside the flame control device.</li> <li>6) Fuse inside the burner bonnet.</li> </ol>	<ol style="list-style-type: none"> <li>1) Raise the value or control the Timer settings.</li> <li>2) Replace it.</li> <li>3) Turn off the electric system and then turn off the switches or wait for the power supply to return.</li> <li>4) Control the installation following the description in the “CONNECTING THE CONTROL DEVICE” paragraph.</li> <li>5) Replace it.</li> <li>6) Open the burner coffer (F Fig. 3 o E Fig. 5) and replace it.</li> </ol>
Flame is not well confirmed with an unpleasant odour, black smoke or flames coming out of the anterior deflector.	<ol style="list-style-type: none"> <li>1) Low pulverisation pressure.</li> <li>2) Insufficient combustible air</li> <li>3 Nozzle clogged because it is dirty or old.</li> <li>4) Water in the fuel. Poor quality fuel.</li> <li>5) The tank is running out of fuel.</li> </ol>	<ol style="list-style-type: none"> <li>1) Reestablish the correct value</li> <li>2) Increase the combustible air.</li> <li>3) Clean or replace the nozzle.</li> <li>4) Drain the fuel from the appropriate drain plug (M Fig. 2).</li> <li>5) Resupply the tank.</li> </ol>

IT - CERTIFICATO CE DI CONFORMITÀ  
GB - CERTIFICATE CE OF CONFORMITY  
DE - KONFORMITÄTSBESCHEINIGUNG  
ES - CERTIFICADO CE DE CONFORMIDAD  
FR - DÉCLARATION DE CONFORMITÉ À LA CE  
NL - CE CONFORMITEITSVERKLARING  
DK - KONFORMITETS - SERTIFIKAT

La sottostritta ditta:  
 The underwrite company:  
 Die undterzeichnende Firma:  
 La Firma que suscribe:  
 La société suivante:  
 Ondergetekende:  
 Ondergetekende:

**DESA Europe B.V. Postbus 271 - 4700 AG Roosendaal - NL**

Dichiaro sotto la propria responsabilità che la macchina:  
 Declares under its responsibility that the machine  
 Erklärt auf eigene Verantwortung, dass die Maschine:  
 Declara bajo su propia responsabilidad, que la máquina:  
 Atteste sous sa responsabilité que la machine:  
 Verklaart verantwoordelijk te zijn voor onderstaande machine:  
 Enkarer pri eget ansvar at mzikin:

**Generatore d'aria calda ad irraggiamento - Radiant hot air generator**  
**Heißluftgenerator - Generator de calor por infrarrojos -**  
**Générateur d'air chaud à rayonnement - Infrarood warmeluchtgenerator -**  
**Varmluft generator med infrarøde stråler**

**XL9 E**  
**XL9 S**

E' conforme alle direttive:  
 The machine complies with:  
 Entspricht den:  
 Está realizada conforme a las directivas:  
 Est conforme aux normes:  
 Is in overeenstemming met de richtijnen:  
 Apparatet modsvarer:

**98/37/CE 91/368/CEE 93/44/CEE 93/68/CEE, 89/336/CEE, 92/31/CEE, 93/68 CEE, 93/97 CEE, 73/23/CEE**

*Augusto Millan*

Augusto Millan (Managing Director)

SCHEMA ELETTRICO - ELECTRIC DIAGRAM - SCHALTPLAN - ESQUEMA ELECTRICO - SCHÉMA ÉLECTRIQUE - BEDRADINGSSCHEMA - ELEKTRISK SKEMA

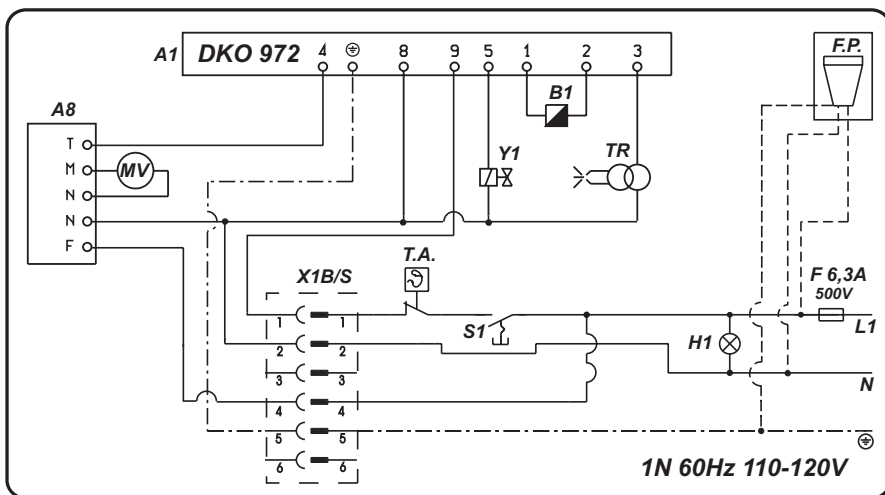
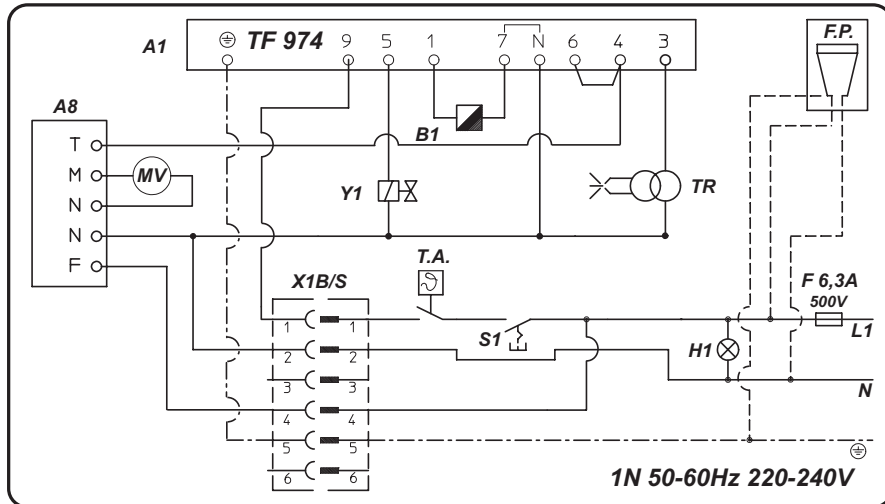

- |    |  |       |   |
|----|--|-------|---|
| L1 | Fase - Phase - Fase - Fase - Phase -   | B1    | Fotoresistenza - Photo-resistance - Fotowiderstand - Fotocélula - Photo-résistance - Fotoresistentie - Modstand med fotocelle                                     |
| N  | Neutro - Neutral - Neutral - Neutro - Nulleiter -  | MV    | Motore ventola - Motor fan - Brennermotor - Motor ventilador -  |
| TA | Termostato ambiente - Thermostat ambient - Umgebungsthermostat - Termostato ambiente - Thermostat ambient - Thermostaat - Omgivende termostat  | TR    | Trasformatore d'accensione - Ignition transformer - Zündungstransformator - Transformador de encendido - Transformateur -   |
| S1 | Interruttore ON/OFF - ON/OFF light - ON/OFF-Schalter - Interruptor ON-OFF - Interrupteur ON/OFF - AAn/UITknop - ON/OFF afbryder  | Y1    | Elettrovalvola - Electric valve - Elektroventil - Electroválvula - Electrovanne - Magnetventil  |
| H1 | Spia di rete - Operate lamp - Funktionsleuchte - Piloto stan-bay - Voyant tension - Lichtnetcontrolelampje - Spændingslampe  | X1B/S | Connettore alimentazione - Power connector - Stromzufuhr - Conexión para alimentación eléctrica - connecteur alimentation - Lichtnetconnector - Forvarmingsfilter |
| A1 | Apparecchiatura controllo fiamma - Control equipment - Steuergerät - Centralita de control - Appareillage contrôle flamme - Vlamcontroleapparaat - Apparat til flammekontrol                           | F.P.  | Filtro pre-riscaldamento - Pre-heating filter - Beheizungsfilter - Filtro pre-calentador de combustible - Filtre de préchauffage - Voorverwarmingsfilter -        |
| A8 | Apparecchiatura post-ventilazione - Post-ventilation Vent - Nach-ventilationskarte - Tarjeta post-ventilación - Fiche post-ventilation - Apparaat naventilatie - Apparat til efterfølgende ventilation |       |   |

SCHEMA ELETTRICO - ELECTRIC DIAGRAM - SCHALTPLAN - ESQUEMA ELECTRICO - SCHÉMA ÉLECTRIQUE - BEDRADINGSSCHEMA - ELEKTRISK SKEMA

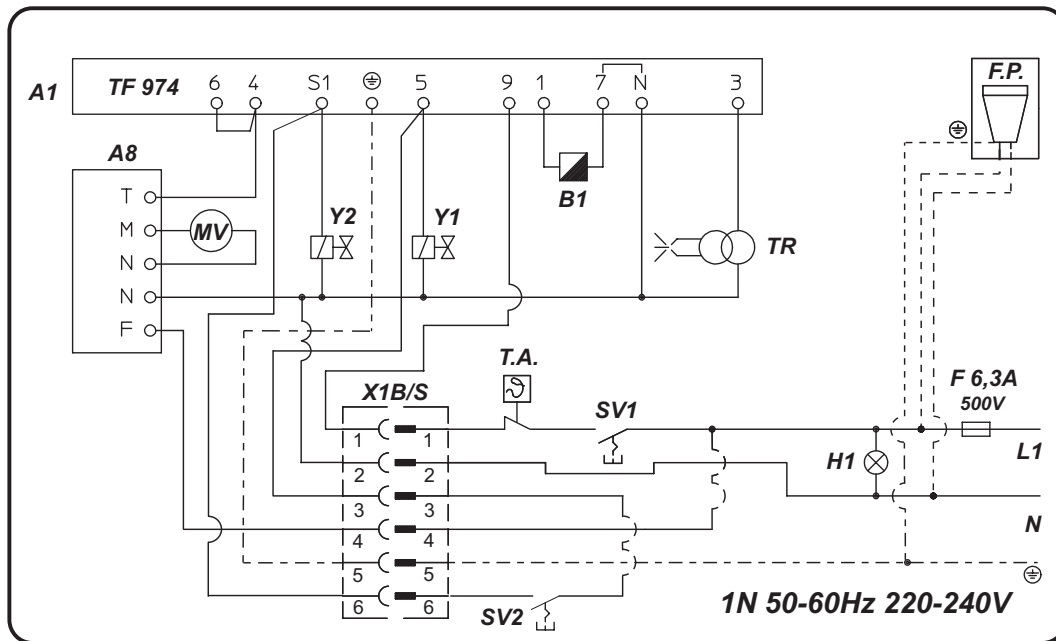

<b>L1</b>	Fase - Phase - Fase - Fase - Phase	<b>B1</b>	Fotoresistenza - Photo-resistance - Fotowiderstand - Foto-célula - Photorésistance - Fotoresistentie - Modstand med fotocelle
<b>N</b>	Neutro - Neutral - Neutral - Neutro - Nulleiter	<b>MV</b>	Motore ventola - Motor fan - Brennermotor - Motor ventilador - Moteur
<b>TA</b>	Termostato ambiente - Thermostat ambient - Umgebungsthermostat - Termostato ambiente - Thermostat ambient - Thermostaat - Omgivende termostat	<b>TR</b>	Trasformatore d'accensione - Ignition transformer - Zündungstransformator - Trasformatore de incendio - Transformateur
<b>SV1</b>	Interruttore ON/OFF - ON/OFF light - ON/OFF-Schalter - Interruptor ON-OFF - Interrupteur ON/OFF - AAn/UITknop - ON/OFF afbryder	<b>Y1</b>	Elettrovalvola 1° stadio - 1° St Stage Electricvalve - Elektroventil 1° Stufe - Electroválvula 1° Etapa- Electrovanne 1°Allure - Magnetventil første trin
<b>H1</b>	Spia di rete - Power indicator - Funktionsleuchte - Piloto stan-bay - Voyant tension - Lichtnetcontrolelampje - Spændingslampe	<b>Y2</b>	Elettrovalvola 2° stadio - 2° St Stage Electricvalve - Elektroventil 2° Stufe - Electroválvula 2° Etapa- Electrovanne 2°Allure - Magnetventil andet trin
<b>A1</b>	Apparecchiatura controllo fiamma - Control equipment - Steuergerät - Centralita de control - Appareillage contrôle flamme - Vlamcontroleapparatuur - Apparat til flammekontrol	<b>X1B/S</b>	Connettore alimentazione - Power connector - Stromzufuhr - Conexión para alimentación eléctrica - connecteur alimentation - Lichtnetconnector
<b>SV2</b>	Interruttore ON/OFF seconda potenzialità - Lighted ON/OFF button second potentiality - ON/OFF Schalter mit Leuchte zweite Potentialität - Interruptor de la segunda potencialidad ON/OFF - Interrupteur lumineux ON/OFF deuxième potentialité - AAn/UITknop -	<b>F.P.</b>	Filtro pre-riscaldamento - Pre-heating filter - Beheizungsfilter - Filtro pre-calentador de combustible - Filtre de préchauffage - Voorverwarmingsfilter - Forvarmningsfilter
<b>A8</b>	Apparecchiatura post-ventilazione - Post-ventilation Vent - Nachventilationskarte - Tarjeta de post-ventilación - Fiche post-ventilation - Apparatuur naventilatie - Apparat til efterfølgende ventilation		

**IT - Smaltimento del prodotto**

- Questo prodotto è stato progettato e fabbricato con materiali e componenti di alta qualità, che possono essere riciclati e riutilizzati.
- Quando ad un prodotto è attaccato il simbolo del bidone con le ruote segnato da una croce, significa che il prodotto è tutelato dalla Direttiva Europea 2002/96/EC.
- Si prega di informarsi in merito al sistema locale di raccolta differenziata per i prodotti elettrici ed elettronici.
- Rispettare le norme locali in vigore e non smaltire i prodotti vecchi nei normali rifiuti domestici. Il corretto smaltimento del prodotto aiuta ad evitare possibili conseguenze negative per la salute dell'ambiente e dell'uomo.

**GB - Disposal of your old product**

- Your product is designed and manufactured with high quality materials and components, which can be recycled and reused.
- When this crossed-out wheeled bin symbol is attached to a product it means the product is covered by the European Directive 2002/96/EC.
- Please inform yourself about the local separate collection system for electrical and electronic products.
- Please act according to your local rules and do not dispose of your old product with your normal household waste. The correct disposal of your old product will help prevent potential negative consequences for the environment and human health.

**DE - Entsorgung Ihres Altgerätes**

- Ihr Produkt ist aus hochqualitativen Materialien und Bestandteilen hergestellt, die dem Recycling zugeführt und wiederverwertet werden können.
- Falls dieses Symbol eines durchgestrichenen Müllcontainers auf Rollen auf diesem Produkt angebracht ist, bedeutet dies, dass es von der Europäischen Richtlinie 2002/96/EG erfasst wird.
- Bitte informieren Sie sich über die örtlichen Sammelstellen für Elektroprodukte und elektronische Geräte.
- Bitte beachten Sie die lokalen Vorschriften und entsorgen Sie Ihre Altgeräte nicht mit dem normalen Haushaltsmüll. Die korrekte Entsorgung Ihres Altgerätes ist ein Beitrag zur Vermeidung möglicher negativer Folgen für die Umwelt und die menschliche Gesundheit.

**ES - Cómo deshacerse del producto usado**

- Su producto ha sido diseñado y fabricado con materiales y componentes de alta calidad, que pueden ser reciclados y reutilizados.
- Cuando vea este símbolo de una papelera con ruedas tachada junto a un producto, esto significa que el producto está bajo la Directiva Europea 2002/96/EC.
- Deberá informarse sobre el sistema de reciclaje local separado para productos eléctricos y electrónicos.
- Siga las normas locales y no se deshaga de los productos usados tirándolos en la basura normal de su hogar. El reciclaje correcto de su producto usado ayudará a evitar consecuencias negativas para el medio ambiente y la salud de las personas.

**FR - Se débarrasser de votre produit usagé**

- Votre produit est conçu et fabriqué avec des matériaux et des composants de haute qualité, qui peuvent être recyclés et utilisés de nouveau.

- Lorsque ce symbole d'une poubelle à roue barrée à un produit, cela signifie que le produit est couvert par la Directive Européenne 2002/96/EC.
- Veuillez vous informer du système local de séparation des déchets électriques et électroniques.
- Veuillez agir selon les règles locales et ne pas jeter vos produits usagés avec les déchets domestiques usuels. Jeter correctement votre produit usagé aidera à prévenir les conséquences négatives potentielles contre l'environnement et la santé humaine.

**NL - Wegwerpen van uw afgedankt apparaat**

- Uw apparaat werd ontworpen met en vervaardigd uit onderdelen en materialen van superieure kwaliteit, die gerecycleerd en opnieuw gebruikt kunnen worden.
- Wanneer het symbool van een doorstreepte vuilnisemmer op wielen op een product is bevestigd, betekent dit dat het product conform is de Europese Richtlijn 2002/96/EC.
- Gelieve u te informeren in verband met het plaatselijke inzamelingsstelsel voor elektrische en elektronische apparaten.
- Gelieve u te houden aan de plaatselijke reglementering en apparaten niet met het gewone huisvuil mee te geven. Door afgedankte apparaten op een correcte manier weg te werpen helpt u mogelijke negatieve gevolgen voor het milieu en de gezondheid te voorkomen.

**PT - Descartar-se do seu produto velho**

- O seu produto está concebido e fabricado com materiais e componentes de mais alta qualidade, os quais podem ser reciclados e reutilizados.
- Quando o símbolo de um caixote do lixo com rodas e traçado or uma cruz estiver anexado a um produto, isto significa que o produto se encontra coberto pela Directiva Europeia 2002/96/EC.
- Por favor informe-se sobre o sistema local para a separação e recolha de produtos eléctricos e electrónicos.
- Actúe por favor em conformidade com as suas regras locais e, não se desfaça de produtos velhos conjuntamente com os seus desperdícios caseiros. Desfazer-se correctamente do seu produto velho ajudará a evitar consequências potencialmente negativas para o ambiente e saúde humana.

**DK - Bortskaffelse af dit gamle produkt**

- Dit produkt er designet og produceret med materialer af høj kvalitet, som kan blive genbrugt.
- Når du ser symbolet med en skraldespand, der er kryds over, betyder det, at produktet er dækket af EU direktiv nr. 2002/96/EC.
- Venligst sæt dig ind i de danske regler om indsamling af elektriske og elektroniske produkter.
- Venligst overhold de danske regler og smid ikke dine gamle produkter ud sammen med dit normale husholdningsaffald. den korrekte bortskaffelsesmetode vil forebygge negative følger for miljøet og folkesundheden.

**FI - Vanhan tuotteen hävittäminen**

- Tuotteesi on suunniteltu ja valmistettu korkealuokkaisista materiaaleista ja komponenteista, jotka voidaan kierrättää ja käyttää uudell.
- Kun tuotteessa on tämä ylivedetyn pyörillä olevan roskakorin symboli, tuote täyttää Euroopan Direktiivin 2002/96/EC.
- Ole hyvä ja etsi tieto lähimmästä erillisestä sähköllä toimivien tuotteiden keräysjärjestelmästä.
- Toimipaikkallisten sääntöjen mukaisesti äläkä hävitä vanhaa tuotetta normaalin kotitalousjätteen joukossa. Tuotteen oikeanlainen hävittäminen auttaa estämään mahdolliset vaikutukset ympäristölle ja ihmisten terveydelle.

**NO - Kaste det gamle apparatet**

- Alle elektriske og elektroniske produkter skal kastes i atskilte gjenbruksstasjoner som er satt ut av statlige eller lokale myndigheter.
- Når dette symbolet med en søppeldunk med kryss på er festet til et produkt, betyr det at produktet dekkes av EU-direktivet 2002/96/EF.
- Riktig avfallshåndtering av det gamle apparatet bidrar til å forhindre mulige negative konsekvenser for miljøet og folkehelsen.
- Hvis du vil ha mer detaljert informasjon om avfallshåndtering av gamle apparater, kan du kontakte lokale myndigheter, leverandøren av avfallshåndteringstjenesten eller butikken der du kjøpte produktet.

**SV - Undangörande av din gamla produk**

- Din produkt är designad och tillverkad med material och komponenter av högsta kvalitet, vilka kan återvinnas och återanvändas.
- När den här överstrukna sopkorgen på en produkt, betyder det att produkten täcks av Europeiska Direktiv 2002/96/EC.
- Informera dig själv om lokala återvinnings och sophanteringssystem för elektriska och elektroniska produkter.
- Agera i enlighet med dina lokala regler och släng inte dina gamla produkter tillsammans med ditt normala hushållsavfall. Korrekt sophantering av din gamla produkt kommer att hjälpa till att för naturen och människors häls.

**PL - Usuwanie starego produktu**

- Zakupiony produkt zaprojektowano i wykonano z materiałów najwyższej jakości i komponentów, które podlegają recyklingowi i mogą być ponownie użyte.
- Jeżeli produkt jest oznaczony powyższym symbolem przekreślonego kosza na śmiecie, oznacza to że produkt spełnia wymagania Dyrektywy Europejskiej 2002/96/EC.

- Zaleca się zapoznanie z lokalnym systemem odbioru produktów elektrycznych i elektronicznych.
- Zaleca się działanie zgodnie z lokalnymi przepisami i nie wyrzucanie zużytych produktów do pojemników na odpady gospodarcze. Właściwe usuwanie starych produktów pomoże uniknąć potencjalnych negatywnych konsekwencji oddziaływania na środowisko i zdrowie ludzi.

**RU - Утилизация старого устройства**

- Ваше устройство спроектировано и изготовлено из высококачественных Материалов и компонентов, которые можно утилизировать и использовать повторно
- Если товар имеет с зачеркнутым мусорным ящиком на колесах, это означает, что товар соответствует Европейской директиве 2002/96/EC.
- Ознакомьтесь с местной системой раздельного сбора электрических и электронных товаров.
- Утилизируйте старые устройства отдельно от бытовых отходов. Правильная утилизация вашего товара позволит предотвратить возможные отрицательные последствия для окружающей среды и человеческого здоровья.

**CZ - Likvidace starého produktu**

- Produkt je navržen a vyroben za použití velmi kvalitních materiálů a komponent, které lze recyklovat a znovu použít.
- Když je produktu připevněn symbol s přeškrtnutým košem, znamená to, že je produkt kryt evropskou směrnicí 2002/96/EC.
- Informujte se o místním tříděném systému pro elektrické produkty.
- Řiďte se místními pravidly a nelikvidujte staré produkty spolu s běžným odpadem. Správná likvidace starého produktu pomůže zabránit případným negativním následkům pro životní prostředí a lidské zdraví.

**HU - Régi termékének eldobása**

- A terméket kiváló anyagokból és összetevőkből tervezték és készítették, melyek újrahasznosíthatóak és újra felhasználhatóak.
- Ha az áthúzott kerek szemetes szimbólumot látja egy terméken, akkor a termék megfelel a 2002/96/EK Európai Direktívának.
- Kérjük, érdeklődjön az elektromos és elektronikus termékek helyi szelektív hulladékgyűjtési rendjéről.
- Kérjük, a helyvi törvényeknek megfelelően járjon el, és régi termékeit ne a normális háztartási szeméttel dobja ki. A régi termék helyes eldobása segít megelőzni a lehetséges negatív következményeket a környezetre és az emberi egészségre nézve.

**DATI TECNICI - TECHNICAL DATA - TECHNISCHE DATEN  
- CARACTERÍSTICAS TÉCNICAS - DONNÉES TECHNIQUES -  
TECHNISCHE GEGEVENS - SPECIFIKATIONER**

<b>MODELLO - MODEL - MODELL - MODELO - MODÈLE</b>	<b>XL9 E</b>	<b>XL9 S</b>
Alimentazione elettrica - Power supply - Elektrischer Anschluss - Alimentación eléctrica - Installation électrique - Elektrische voeding - El-type	220/240 V - 1~50 Hz 110/120 V - 1~60 Hz	220/240 V - 1~50 Hz
Assorbimento - Total Consumption - Stromstärke - Consumición Total - Puissance totale - Stroomsterkte - Strømstyrke	0,6 A	0,7 A
Fusibile - Fusible - Sicherung - Fusible - Fusible	6,3A - 500V	6,3A - 500V
Consumo - Consumption - Kraftstoffverbrauch/Durchsatz - Consumo máximo combustible - Consommation - Brandstofverbruik - Petroleumsforbrug	3,2 kg/h	P <sub>1</sub> 2,3 kg/h P <sub>2</sub> 3,1 kg/h
Potenza termica standard- Capacity standard- Wärmeleistung des Brenners - Potencia térmica standard - Puissance thermique standard - Standaard thermische potentie - Standard varmeydelse	40 kW	27 kW / 40 kW
Potenza termica max - Thermal power max - Höchstkapazität - Potencia térmica máxima - Puissance thermique max - Maximale thermische potentie - Maksimal varmeydelse	43 kW	29 kW / 43 kW
Combustibile - Fuel - Brennstoff - Combustible - Carburant - Brandstof	KEROSENE - DIESEL OIL	KEROSENE - DIESEL OIL
Capacità serbatoio - Tank Capacity - Fassungsvermögen des Brennstofftanks - Capacidad del depósito - Capacité du réservoir - Capaciteit tank - Tankkapacitet i liter	60 lt	60 lt
Autonomia - Autonomy - Brennstoff - Autonomía - Autonomie - Autonomi	16 h	24 h / 16 h
Trasformatore - Transformer - Transformator - Trasformatore de encendido - Transformateur -	40 mA - 15 KV	30 mA - 2x10 KV
Ugello - Nozzle- Düse - Boquilla de pulverización - Inieteur - Straalpijp	0,85 GpH 60°H	0,60 GpH 60°H
Pressione pompa - Pump pressure - Pumpendruck - Presión de la bomba - Pression de la Pompe - Druk brandstofpomp - Pumpetryk	10 bar	10 bar / 18 bar
Regolazione serranda aria - Air vent regulator - Regulierung der Luftklappe - Regulación aire de la combustión - Régulation volet d'air - Regulatie luchtsluiters - Justering af luftspjældet	4 - 4,5	4 - 4,5
Regolazione della testa di combustione - Vent Regulation- Regulierung des Brennkopfes - Regulación de la cabeza de la combustión - Régulation tête de combustion - Regulatie van de verbrandingskop - Justering af forbrændingshovedet	4	4
Dimensioni, L x P x A - Dimension LxWxH - Maße L x B x H - Dimensiones - Dimensions - Afmetingen L x B x H - Dimensioner L x B x H	120x76x113 cm	120x76x113 cm
Peso - Weight - Gewicht - Peso - Poids - Gewicht inclusief verpakking - Vægt	62 kg	62 kg

Váš dodavatel:



**VaŠE**  
*Plus+.cz*

Rodovská 883, 190 14 Praha 9  
Tel.: +420 776 607 741, DIČ: CZ28887751  
Email: info@vaseplus.cz, www.vaseplus.cz

[www.vaseplus.cz](http://www.vaseplus.cz)